

Thank you for purchasing an 'Outdoor Revolution' product, this product will give years of satisfactory service if basic instructions are followed; our products are designed for durability and ease of erection.



WWW.OUTDOOR-REVOLUTION.COM

UNIT 1 BRICK PARK
BRETFIELD COURT
BRETTON STREET INDUSTRIAL ESTATE
DEWSBURY
WEST YORKSHIRE
WF12 9BY



ESPRIT PRO TALL ANNEXE

INSTRUCTIONS & CARE MANUAL



IMPORTANT: PLEASE CHECK YOUR EQUIPMENT

1 x 800HD FLYSHEET (OR OUTER)

1 x OXYGEN AIR-FRAME TUBE

1 x TWO-BERTH MICRO-POLYESTER INNER TENT

1 x BAG OF PEGS

1 x REPAIR KIT

1 x CARRY BAG

GUYLINES

LUMI-LITE HANGING POINTS

EUROPA & ESPRIT ANNEXE

Outer Height: 170CM

Inner Height: 155CM

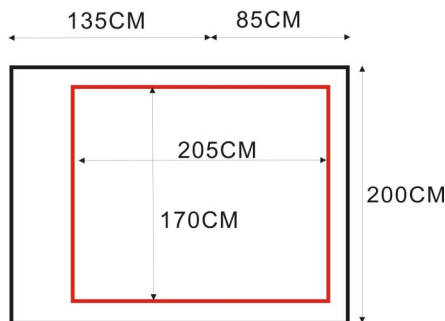

We highly recommend that you insure your annexe against storm damage or accidental damage, as the warranty does not cover such eventualities. The manufacturer **IS NOT** liable for any damage caused to the annexe or its contents as a result of misuse, incorrect pitching or extreme weather (full warranty details on rear of booklet).

THE WARRANTY (CONTINUED...)

- Flaws in the fabric caused by excessive use.
- Imperfections and pulls in mesh doors due to wear and tear.
- Water ingress through fabric, as a result of UV degradation.
- Water ingress through seams, caused by excessive abrasion of seams or taped seam.
- Broken zips, caused by over tensioning, forcing or snagging.
- Over tensioned/stretched seams coming apart.
- Buckles subjected to undue force or abrasion.
- Lost/popped out eyelets.
- Broken holdalls.
- Pole breakages or tube punctures (where applicable).
- Collateral damage from a pole breakage .
- UV degradation.
- Condensation, (a natural occurrence, exacerbated by insufficient ventilation opening).
- Consequential damage/loss to property/belongings (either inside or outside of the product) or shortening of holidays

Outdoor Revolution work very closely with our retail partners to manage all warranty repairs/issues:

**Please contact your retailer immediately (even if purchased online), if you feel your "Outdoor Revolution" product has a genuine warranty issue. The retailer, in turn, will raise the issue with ourselves and we will action, with the retailer, according to the nature of the claim.

**Please ensure that the product is clean and dry and as close to its original condition as possible, before sending back for checking.

**Wet or dirty products will not be accepted back for checking/warranty claims.

** It is important to note that the sales contract between yourself and the retailer you purchased the "Outdoor Revolution" product from, remains valid throughout any warranty claim and your statutory rights are not affected.

OUTDOOR REVOLUTION GUARANTEE

“Outdoor Revolution” products are designed and produced to the highest possible manufacturing standards. The best quality fabrics and components available are used for each specific item and a rigorous checking process of finished products is in place.

All finished products are:-

- Checked for and are free of minor defects
- Are fit for the purpose/use that they are intended
- Are of a satisfactory quality

It is important that correct care is taken when opening, erecting, using and just as importantly, packing away the product. Following these rules will keep your product in reliable working condition for many years. Failure to adhere to these simple guidelines may cause unnecessary damage to the product (see formal instructions for hints and tips on handling/erecting the product). A repair kit is included with the product to help resolve any minor issues.

THE WARRANTY

The “Outdoor Revolution Warranty” lasts for 12 months from the original date of purchase (please keep all receipts or copies of any relevant transaction to substantiate the purchase date). The warranty only covers workmanship and fabric/components. Any faults found within 6 months of purchase will be investigated by “Outdoor Revolution”. Faults found outside of the initial six months of purchase will need to be proven by you, the purchaser, in line with current consumer legislation, after the short term right to reject has ended.

Retailer will not refund a purchase if no fault is found.

Product warranty must be registered **BEFORE** use, via: www.outdoor-revolution.com and as soon as possible from the date of purchase.

The manufacturer’s warranty does not cover the following:-

- General wear and tear over extended periods of use or seasonal pitching of the product.
- Accidental damage caused by but not exclusive to, humans, animals or weather.

IMPORTANT INFORMATION

- ◆ Please do not leave for your holiday without fully erecting and checking you have all the contents for your annexe; if you are missing anything, please contact your retailer immediately before use.
- ◆ Please also note that man-made fabrics are prone to condensation when the warm air and moisture inside the annexe comes into contact with the colder outside of the annexe fabric. You may also experience condensation in the tube sleeves; this is a perfectly natural occurrence and should not be confused with leaking. Ensure all ‘Vortex Vents’ are open whenever possible to help combat condensation.
- ◆ Ideally, erect your annexe for some period before use - allowing it to weather. ‘Weathering’, can take a few uses of the annexe before it becomes fully effective; seam sealant can be used to solve any persistent weeps. This process is completely normal. ‘Weathering’ is the process of allowing your canvas product get wet, then dry approximately two to three times in order to strengthen and further waterproof the seams and stitching on the fabric.
- ◆ Make sure that before erecting, you site the annexe on clear, level ground, with no sharp objects underneath and that all zips are fully closed (we suggest laying a groundsheet down to keep the annexe dry and clean).
- ◆ We suggest conducting a trial run of your annexe to familiarise yourself with the set up and use of the annexe. If you have any issues relating to pitching your annexe, please contact your dealer for help before going on holiday.
- ◆ Please note this annexe is designed for ‘touring’ not for permanent pitch.
- ◆ After use, always dry and air the annexe before packing away to prevent mildew or mould.
- ◆ Any dirt or stains can be removed by brushing or gently washing with warm water. **DO NOT** use detergents, as this will destroy the waterproofing of the fabrics.
- ◆ **DO NOT** cook or smoke in this annexe; although the outer fabric is flame retardant treated; it will still melt.
- ◆ In the event of damage; please contact your retailer. If for whatever reason, you are unable to contact them, please email: cs@blue-diamond-products.co.uk and our customer service team will be happy to help!

OPTIONAL ACCESSORIES

- ◆ Trio Sleeping Bags - Luxurious co-ordinating sleeping bags with our signature trio-stripped branding, available in various sizes for a perfect night's sleep!
- ◆ Trio Sleeping Pillow - Matching pillow to fit our sleeping bag ranges' pillow envelope, complete with our signature trio-stripped design.

⇒ Visit: www.outdoor-revolution.com for more information on the optional extras.

12 MONTH WARRANTY

On workmanship and canvas.

TROUBLE SHOOTING

<u>PROBLEM</u>	<u>REASON</u>	<u>SOLUTION</u>
The air-tube keeps deflating after removing the pump.	The 'Dynamic Speed Valve' button hasn't been pressed back out.	Press the quick-release button back out to shut the valve.
The annexe is leaking.	The annexe requires 'Weathering' two to three times before it fully seals itself, so you may experience a little bit of weeping. This could also be condensation; an inevitable occurrence.	Allow the annexe to get wet, then dry two to three times. Open all ventilation points to increase air flow and reduce condensation.
Bowing and twisting of the tubes.	The tubes can twist inside the sleeves, particularly when packing away, so next time the tube bows. ..	Un-zip the sleeve whilst the tube is deflated and re-position the tube.

IN THE EVENT OF A PUNCTURE

If you have a small puncture in your air-frame tube, you can easily repair it using the standard puncture repair kit.

- ◆ To remove the air-frame tube; deflate the tube and then un-zip the two protective sleeves over the tube and pull the air-tube out. Do not un-zip the sleeves whilst the tube is inflated.
- ◆ Locate and repair the puncture on the air-frame bladder.
- ◆ Place the air-tube back into the sleeves, in the correct place, with the valves in the valve hole. Make sure that the tube is straight and not twisted.
- ◆ Zip the two sleeves back up fully.
- ◆ Inflate the air-frame tube again, ensuring that the puncture has now been repaired.
- ◆ If this process doesn't work; you may have to buy a new bladder.

**Spare air-frame bladders can be purchased to replace damaged ones. Visit the spares section at: www.outdoor-revolution.com, or contact us on 01924

455313**

Annexes will not be replaced because of damaged bladders

PACKING AWAY YOUR AWNING

- ◆ Unpeg the guylines and most of the pegs around the annexe, leaving the four corners pegged out.
- ◆ Open the 'Dynamic Speed Valve' and press in the quick release button. Leave the button pressed in to allow all of the air to escape as you roll it.
- ◆ Unpeg the four corners and un-zip the annexe from the awning door.
- ◆ Lay the annexe flat on the ground and push as much air out of it as possible.



1. Fold the annexe lengthways, from the opposite ends to the valves to push all the air out. Make a long, thin sausage shape.



2. Measure the width of the bag up against the width of the folded annexe to make sure the annexe is going to fit.



4. Place the rolled annexe onto the bag and pull the sides up around it. Finally, zip-up the bag.



PLEASE READ THE INSTRUCTIONS CAREFULLY

TIP: Refer to the photographs to help when pitching your 'Esprit Pro Tall Annexe'.

1. Spread the annexe flysheet out on the ground next to your caravan awning, with the zip next to the door you wish to attach it to.



2. Zip-out the door panel on the compatible 'Esprit' awning, on the side you wish to attach the annexe; store the door panel away somewhere dry and clean.

3. Zip the integral annexe zip onto the door zip, ensuring you don't pull the material too viciously and making sure that no fabric gets caught in the zip.



4. Locate the 'Dynamic Speed Valve' and ensure the valve is **closed**, before attaching the pump (the valve is closed when the button is pressed out).

5. Next, attach the pump to the 'Dynamic Speed Valve' and begin to carefully inflate, taking care that no part of the fabric is caught anywhere.



6. Inflate the air-frame until you can give it a good squeeze; the tube needs to have room inside for air to expand. Don't worry if you do keep inflating - the 'Intelligent Frame Relief Valve' will release any excess air (please note the 'Intelligent Frame' is set to a limit of 5.5PSI, before it will release air).

7. Replace the cap on the 'Dynamic Speed Valve' and cover the valves with the flap to prevent water getting inside.



8. Peg out and tension the front of the annexe; use the adjustable pegging straps to tension the annexe as you desire; make sure you don't over-tension the fabric. If it is too tight, release some tension.

9. Lay the inner tent in the annexe and start at the back by clipping the matching 'C' clips to the floor and inserting the coloured elastic into the coloured loop.



10. Work your way around the inner tent, clipping all of the elastics and clips in. Work your way forward until the inner tent is fully clipped-in.

10. Peg out all guylines around the annexe to ensure it is securely in place.



11. Finally - put all of your sleeping equipment inside the annexe and enjoy your holiday!

WARNING: Never un-zip the zips on the protective sleeves whilst the air-frame tubes are inflated; this will result in the tube bursting/ballooning out of the sleeve, causing damage to the tube and the sleeve. This is NOT covered under the warranty!